

English:

• Apply item N°2 (Screw – x1) to tighten the Stainless Steel Fixing (item N°5) to the motorcycle frame – Right Side.

► **ATTENTION: Use the protection hole marked in the photo.**

Français:

• Appliquer l'item N°2 (Vis – x1) pour serrer la Fixation Inox (item N°5) au cadre de la moto - Côté Droit.

► **ATTENTION: Utilisez le trou de protection marqué sur la photo.**

Português:

• Aplicar o item N°2 (Parafuso – x1) para apertar a Fixação Inox (item N°5) ao quadro da moto – Lado Direito.

► **ATENÇÃO: Utilizar furo da proteção assinalado na foto.**

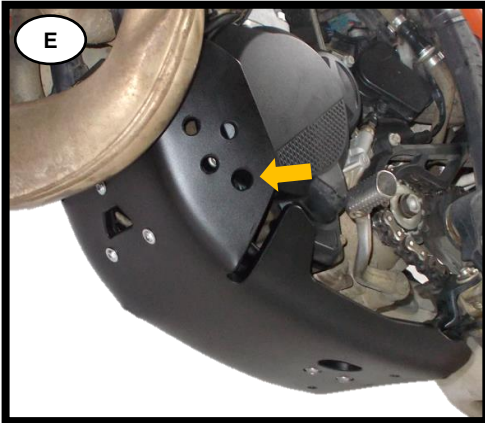

English:

• Apply item N°2 (Screw – x1) to tighten the Stainless Steel Fixing (item N°5) to the motorcycle frame – Left Side.

► **ATTENTION: Use the protection hole marked in the photo.**

Français:

• Appliquer l'item N°2 (Vis – x1) pour serrer la Fixation Inox (item N°5) au cadre de la moto - Côté Gauche.

► **ATTENTION: Utilisez le trou de protection marqué sur la photo.**

Português:

• Aplicar o item N°2 (Parafuso – x1) para apertar a Fixação Inox (item N°5) ao quadro da moto – Lado Esquerdo.

► **ATENÇÃO: Utilizar furo da proteção assinalado na foto.**

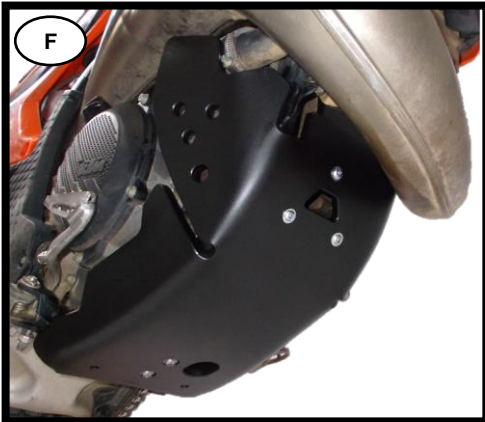

English:

• Torque all screws to the correct value.

Français:

• Torque toutes les vis avec la bonne valeur.

Português:

• Apertar todos os parafusos com o valor correto de torque.



**DTC HARD X 8.0
ENGINE GUARD**
Ref.: 2CP240230A



Assembly Booklet / Paper collection
Livret de montage / Collecte de papier



Mini Zip Bag / Plastic collection
Mini sac zip / Collecte de pastique



Box / Paper collection
Boîte / Collecte de papier



Carton Separator / Paper collection
Séparateur de cartons / Collecte de papier



Card Header / Paper collection
Carte d'en-tête / Collecte de papier



Plastic Bag Cover / Plastic collection
Couverture de sac en plastique / Collecte de plastique



ASSEMBLY INSTRUCTION / INSTRUÇÃO DE MONTAGEM

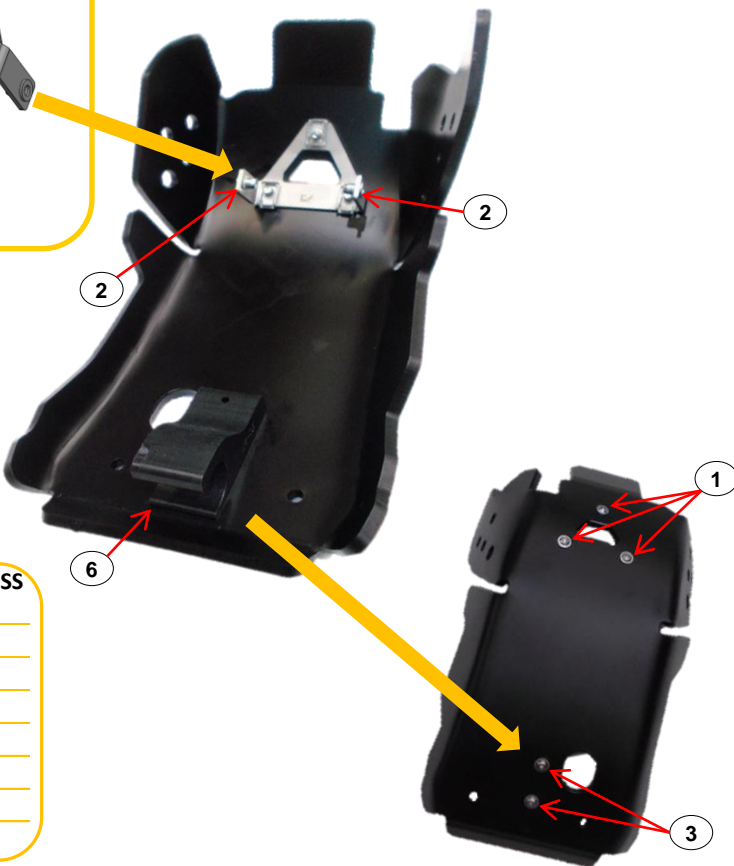
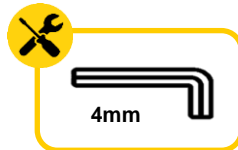
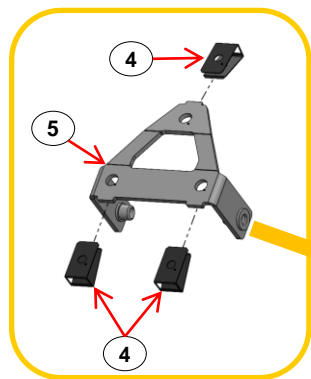

N ^o m	STAINLESS	
	STEEL	STEEL
	8.8	A2
M4	2.7	2.6
M5	5.5	5.1
M6	9.7	8.7
M8	23.0	21.2
M10	47.0	42.0
M12	80.0	73.0

6	Fixação DTC / DTC Clamp	Nº118	1
5	Fixação Inox / Stainless Steel Clamp	Nº184	1
4	Mola de Friso / Clip Inox	M6	3
3	Paraf. Especial DTC / DTC Special Screw	7x25	2
2	Parafuso com FA / Screw With Washer False	M6x35 ISO7380 - 8.8	2
1	Parafuso com FA / Screw With Washer False	M6x20 ISO7380 - 8.8	3
ITEM Nº:	COMPONENTE (COMPONENT):	DESCRIÇÃO (DESCRIPTION):	QUANT.:
ACESSÓRIOS (ACCESSORIES)			

DATE: 14/03/2024

DTC HARD X 8.0 ENGINE GUARD

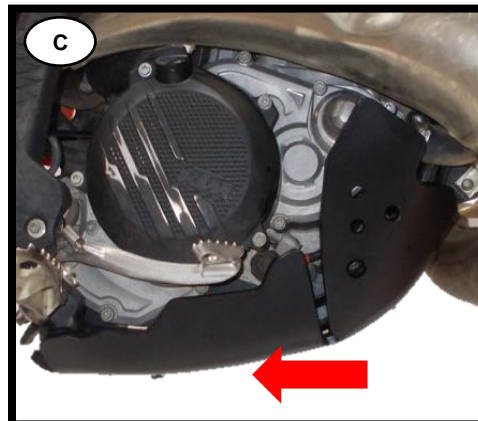
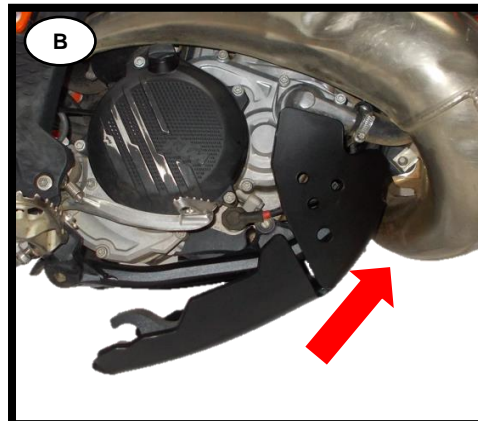

English:

• Apply items N°6 (DTC Clamp – x1) and N°5 (Stainless Steel – x1) to the protection according to the assembly instruction.

► **ATTENTION: Do not tighten the screws to help the assembly.**

Français:

• Appliquer les items N°6 (DTC Fixation – x1) et N°5 (Inox Fixation – x1) sur la protection selon les instruction de montage.

► **ATTENTION: Ne pas serrer les vis pour faciliter le montage.**

Português:

• Aplicar os itens N°6 (Fixação DTC – x1) e N°5 (Fixação Inox – x1) na proteção de acordo com a instrução de montagem.

► **ATENÇÃO: Não dar aperto aos parafusos para ajudar na montagem.**

English:

• Install protection according to the direction of the arrow.

Français:

• Monter la protection en accord avec le sentiment de sécurité.

Português:

• Montar proteção de acordo com o sentido da seta.

English:

• Move the protection according to the arrow in order to engage the rear clamp.

Français:

• Déplacez la protection selon la flèche afin d'enclencher la fixation arrière.

Português:

• Movimentar proteção de acordo com a seta de forma encaixar a fixação de trás.